

Drive technology

Individual solutions for any application

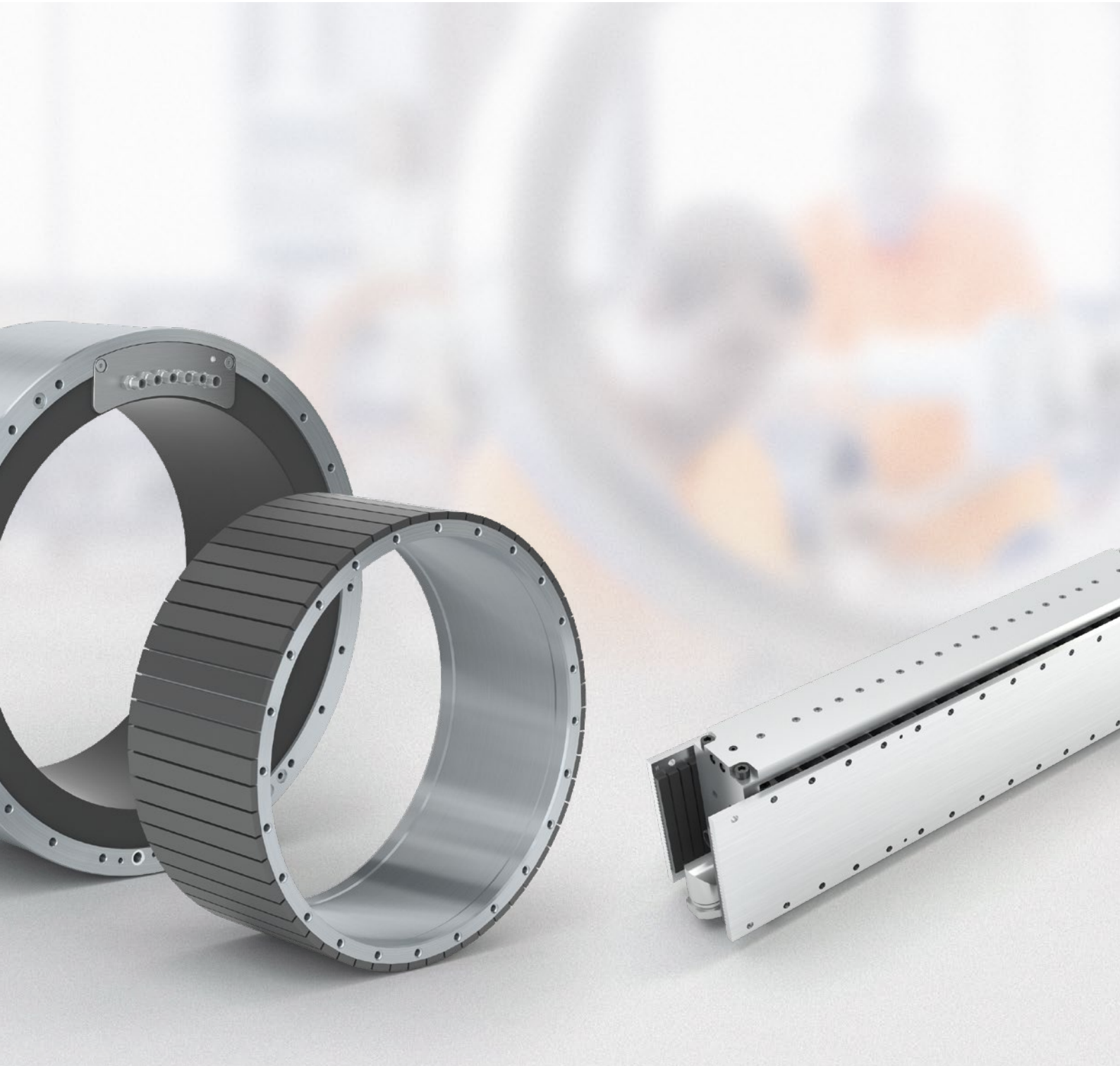

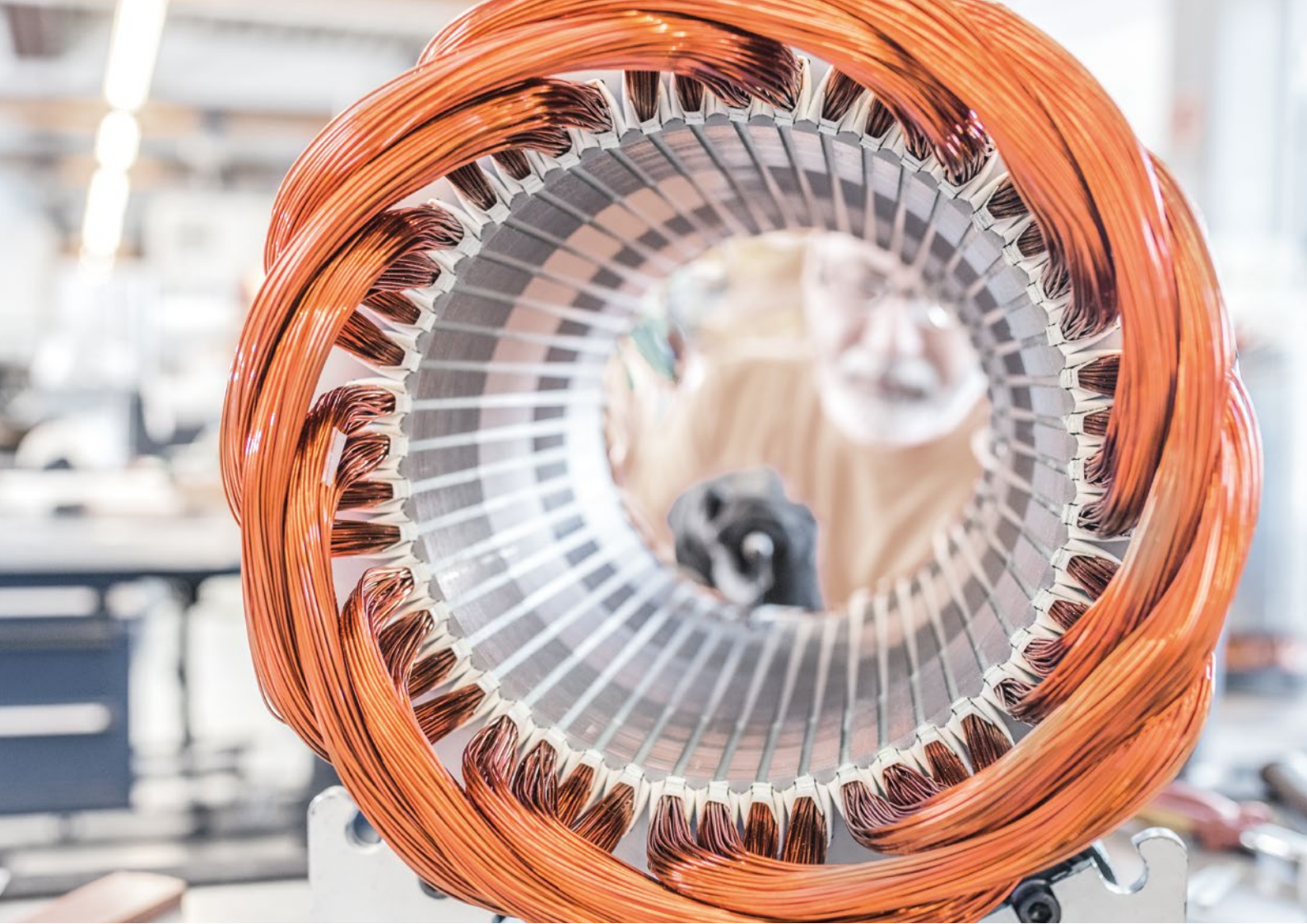

Integrate any direct drive into any environment

KESSLER energy GmbH operates within the KESSLER Group, using optimized assembly lines for the production of electrical drives.

KESSLER energy accompanies the product from the electrical and mechanical construction, to the numerical calculations using the finite element methods and analytical calculation programs to the testing, commissioning and parameter optimization of the end result. KESSLER motors meet the highest efficiency requirements.

The company also reinforces the drive technology expertise of the KESSLER Group in new application areas.

End-to-end precision from the components to the on-site service

Founded in 1923 by Franz Kessler, the company has developed to become the leading supplier of motor spindles as well as directly driven 2-axis heads and rotary tilt tables for the machine tool industry. KESSLER is proud to list many major companies from the mechanical engineering sector amongst its long-standing customers.

With the expertise of more than 95 years, KESSLER is continuously developing and optimising its products. The KESSLER product range serves a wide range of sectors, processes and applications. Close cooperation with our customers remains our key focus. The extensive product range, from hightech spindles, 2-axis heads, rotary and rotary tilt tables to motors and direct drive systems, enables KESSLER to implement customised solutions with speed and flexibility.

Service is a matter of trust. Rely on us as your trusted service partner: KESSLER has an established global network of technology and service centres.



KESSLER energy Profile

- **Energy-efficient motors** with top power density and degree of efficiency
- **Short delivery times** (within 6 weeks for products up to size 530, in current series production and with fixed lot sizes)
- **Production at competitive prices for the global market**
- Standard motors with **minimized construction height and cogging torque**
- Standard motors **with 100 % installation compatibility**
- **Special motor assembly kits and motor assembly groups** according to customer requirements
- **Standard motor sizes up to a diameter of 3 meters**
- **Torque ripple less than 1 %**
- **Integration** of any direct drive into any environment
- **Applications for very high torque** (KESSLER HTM and HTMx series) and very high speed (KESSLER STMx series)
- **Application examples:** direct drive for sport motorboats, renewable energy applications, automotive drives and plant engineering

Portfolio

Standard motors

- Asynchronous motors
- Synchronous motors
- Torque motors
- Linear motors

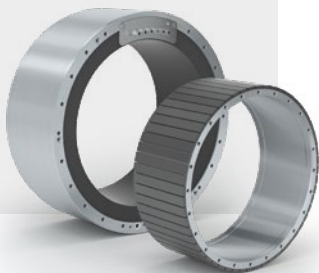

Special motors

- Asynchronous motors
- Synchronous motors
- Torque motors
- Linear motors



Direct drive systems

- Integrated motor systems with bearings and measurement system according to customer requirements





Automated rotor-magnet adhesive

Direct drive technology by KESSLER

With over **95 years of experience** in motor technology, KESSLER energy designs and manufactures energy-efficient drives for every range of performance, in accordance with individual customer requirements.

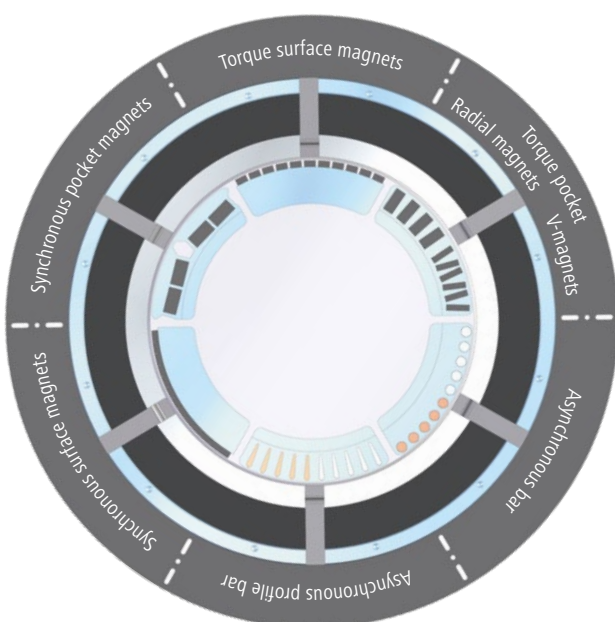

Top energy and power density

	Torque [Nm]	Speed [rpm]
Torque pocket, V-solenoids	■■■■■ M[Nm]	■■■■■ n[rpm]
Torque radial pocket solenoids	■■■■■ M[Nm]	■■■■■ n[rpm]
Torque surface solenoids	■■■■■ M[Nm]	■■■■■ n[rpm]
Synchronous pocket solenoids	■■■■■ M[Nm]	■■■■■ n[rpm]
Synchronous surface solenoids	■■■■■ M[Nm]	■■■■■ n[rpm]
Asynchronous copper rod	■■■■■ M[Nm]	■■■■■ n[rpm]
Asynchronous aluminium rod	■■■■■ M[Nm]	■■■■■ n[rpm]
Asynchronous copper bar	■■■■■ M[Nm]	■■■■■ n[rpm]
Asynchronous aluminium bar	■■■■■ M[Nm]	■■■■■ n[rpm]



COOLMOTION®

KESSLER COOLMOTION®

COOLMOTION® in drive technology

- achieves a **very high torque density** with up to **30 % more torque in a minimized design**
- facilitates a **compact design**
- achieves a significantly **more robust** design in relation to resonance and reflection effects
- facilitates **applications even during continuous loads**
- provides **maximum standstill torque**

KESSLER is the innovation engine behind state-of-the-art direct drive technology and is renowned for powerful and energy-efficient motors with high torque density and top reliability even in high-demand applications. Practically-based simulations and individual customer calculations are a prerequisite for the development excellence of KESSLER motors.

The inverter-optimized COOLMOTION® motors are recognized for their low-loss design and enhanced heat dissipation. Innovative modifications of the motor components have enabled us to reduce the rotor and stator losses by 25 %. Special construction measures have resulted in significantly enhanced heat dissipation.

The COOLMOTION® technology optimizes efficiency to a maximum.

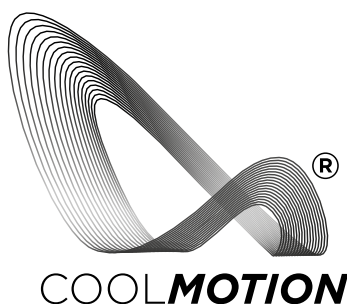

Optimization principle

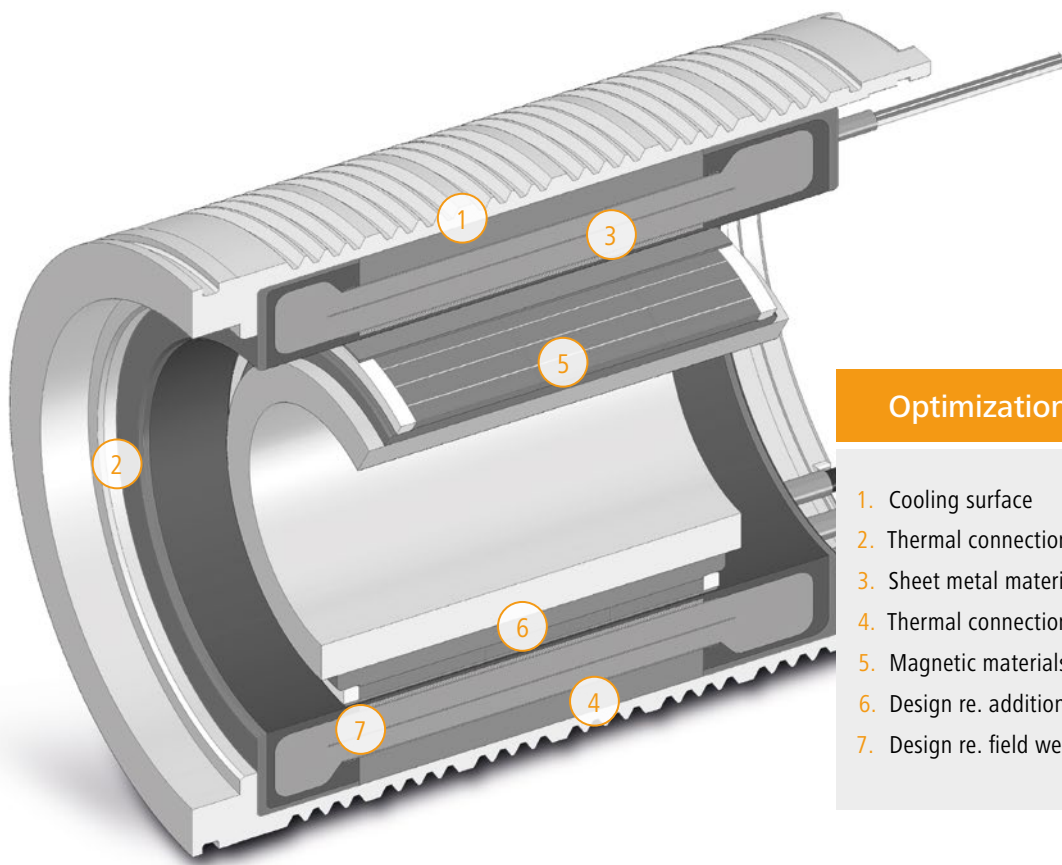
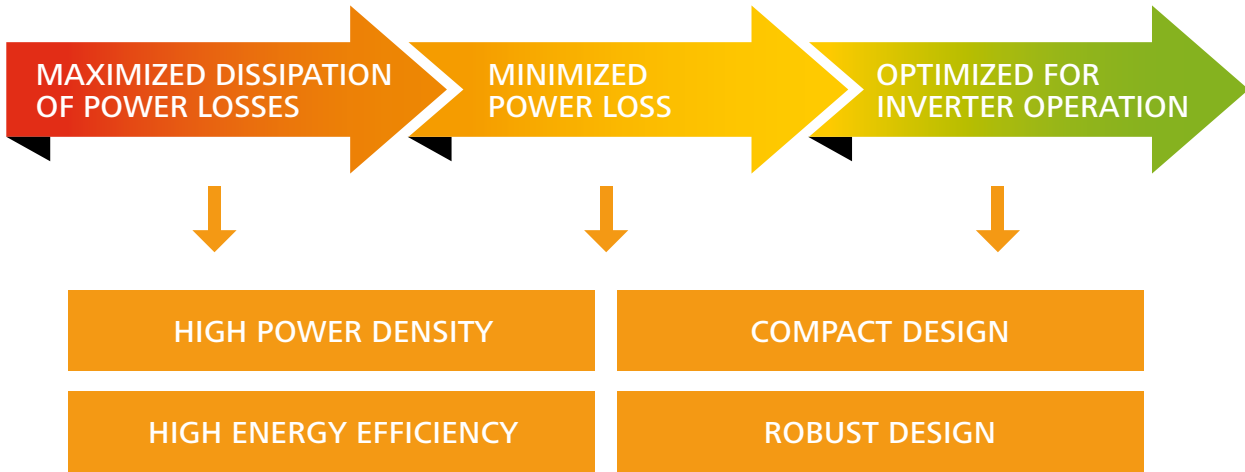

- Optimization measures**
1. Cooling surface
 2. Thermal connection of coil ends
 3. Sheet metal material
 4. Thermal connection of stator slots
 5. Magnetic materials
 6. Design re. additional power loss
 7. Design re. field weakening



A new generation of KESSLER torque motors

Energy-efficient direct drives for any field of application

High torque motor HTMx

Optimized torque

Speed torque motor STMx

High speed

High torque motor HTM

Installation compatibility

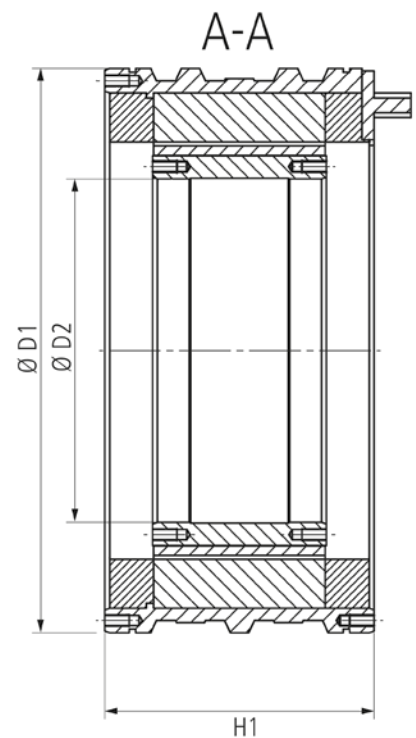

Model	D1 / D2 and H1
HTMx	Installation compatibility*
STMx	optimized
HTM	Installation compatibility*

*in comparison to the usual market standard; for design without cooling jacket

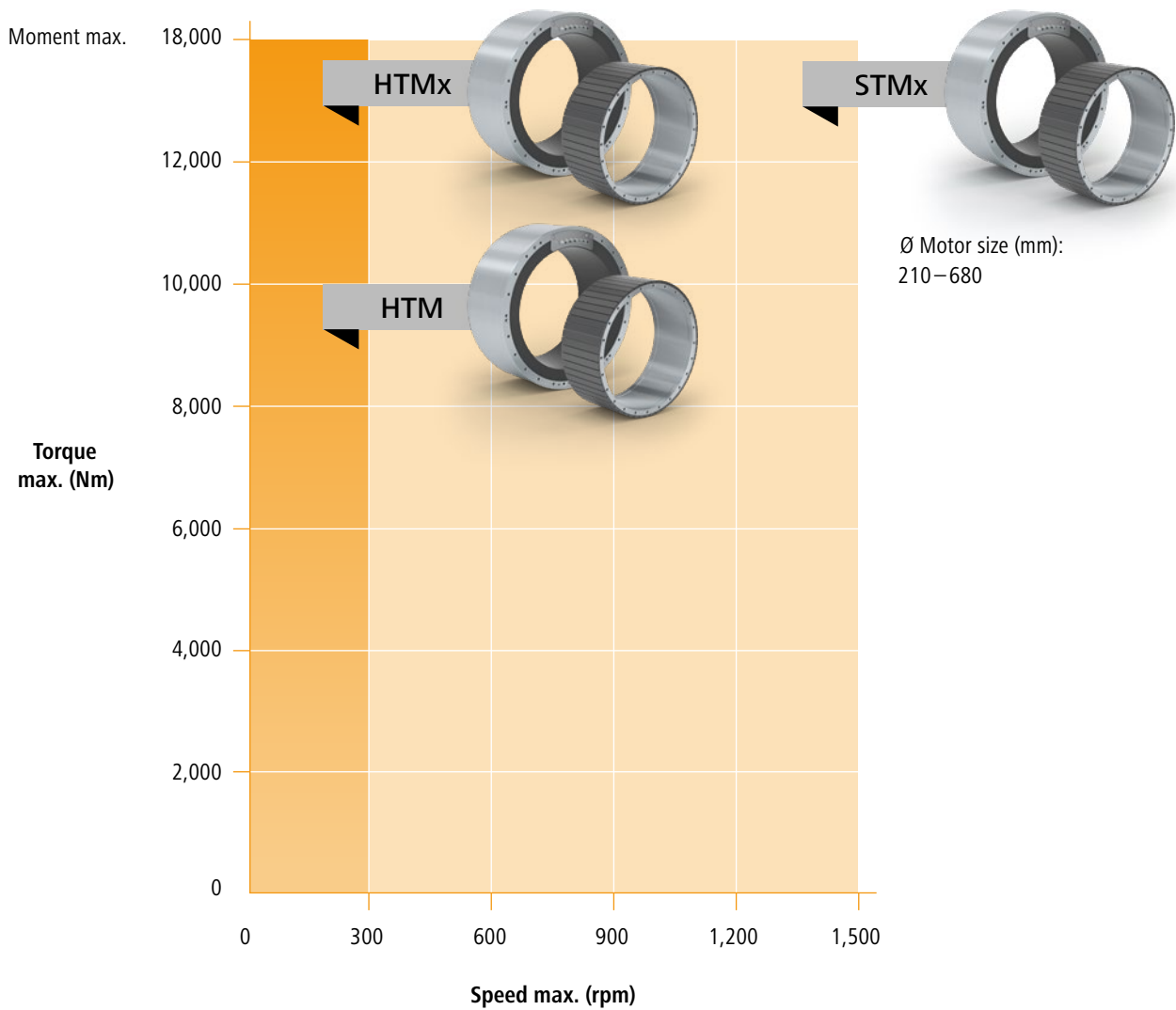

Excerpt from HTMx series

Model	Size	H1 (mm)	N max. (rpm)	MS1 (Nm)	MS6 max. (Nm)
HTMx 210 D1 = 230 mm D2 = 140 mm	30	70	200	74	148
	50	90	200	117	234
	70	110	200	163	326
	100	140	200	230	460
	150	190	200	342	684
	200	240	200	454	909
HTMx 290 D1 = 310 mm D2 = 220 mm	30	70	200	175	350
	50	90	200	290	580
	70	110	200	400	800
	100	140	200	560	1,120
	150	190	200	840	1,680
	200	240	200	1,139	2,277
HTMx 360 D1 = 385 mm D2 = 265 mm	30	90	100	360	720
	50	110	100	550	1,100
	70	130	100	740	1,480
	100	160	100	1,025	2,050
	150	210	100	1,512	3,024
	200	260	100	2,016	4,032
HTMx 420 D1 = 455 mm D2 = 325 mm	30	90	100	580	1,160
	50	110	100	840	1,680
	70	130	100	1,100	2,200
	100	160	100	1,510	3,020
	150	210	100	2,210	4,420
	200	260	100	2,933	5,867
HTMx 450 D1 = 485 mm D2 = 345 mm	30	90	100	680	1,360
	50	110	100	990	1,980
	70	130	100	1,300	2,600
	100	160	100	1,750	3,500
	150	210	100	2,480	4,960
	200	260	100	3,200	6,400
HTMx 530 D1 = 565 mm D2 = 420 mm	30	90	100	870	1,740
	50	110	100	1,300	2,600
	70	130	100	1,740	3,480
	100	160	100	2,380	4,760
	150	210	100	3,450	6,900
	200	260	100	4,525	9,049
HTMx 680 D1 = 710 mm D2 = 522 mm	30	100	50	1,790	3,580
	50	120	50	2,650	5,300
	70	140	50	3,530	7,060
	100	180	50	4,800	9,600
	150	220	50	6,920	13,840
	200	260	50	9,045	18,089

Excerpt from STMx series

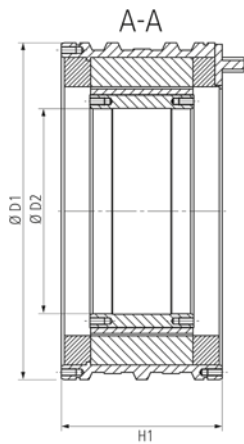

Model	Size	H1 (mm)	N max, (rpm)	MS1 (Nm)	MS6 max, (Nm)
STMx 210 D1 = 230 mm D2 = *	30	70	1,500	81	160
	50	90	1,500	130	260
	70	110	1,500	180	340
	100	140	1,500	250	460
	150	190	1,500	380	710
	200	240	1,500	500	920
STMx 290 D1 = 310 mm D2 = 178 mm	30	70	1,400	200	385
	50	90	1,400	325	600
	70	110	1,400	440	835
	100	140	1,400	620	1,150
	150	190	1,400	900	1,650
	200	240	1,400	1,160	2,150
STMx 360 D1 = 385 mm D2 = 216 mm	30	90	1,400	390	730
	50	110	1,400	595	1,050
	70	130	1,400	820	1,410
	100	160	1,400	1,140	1,920
	150	210	1,400	1,660	2,800
	200	260	1,400	2,150	3,600
STMx 420 D1 = 455 mm D2 = *	30	90	1,000	650	1,140
	50	110	1,000	920	1,600
	70	130	1,000	1,215	2,140
	100	160	1,000	1,580	2,760
	150	210	1,000	2,440	4,100
	200	260	1,000	3,130	5,300
STMx 450 D1 = 485 mm D2 = 295 mm	30	90	1,000	750	1,410
	50	110	1,000	1,100	1,990
	70	130	1,000	1,400	2,600
	100	160	975	1,880	3,490
	150	210	980	2,800	5,120
	200	260	800	3,600	6,565
STMx 530 D1 = 565 mm D2 = 365 mm	30	90	1,000	960	1,800
	50	110	1,000	1,400	2,650
	70	130	1,000	1,950	3,560
	100	160	1,000	2,600	4,775
	150	210	1,000	3,800	6,800
	200	260	750	4,900	8,750
STMx 680 D1 = 710 mm D2 = *	30	100	800	1,900	2,830
	50	120	800	2,910	4,190
	70	140	800	3,800	5,400
	100	180	800	5,120	7,230
	150	220	800	7,600	10,680
	200	260	700	9,900	13,800

* Diameter on request

Motor configurator – for fast, efficient online configurations of the best matching product

For details of the KESSLER motors, contact us for a personal meeting or take a look at the online motor configurator.

Depending on your requirements, you can also customize the design size, torque and speed of your own motor and submit a request for a non-binding offer: motorcatalog@kessler-group.biz

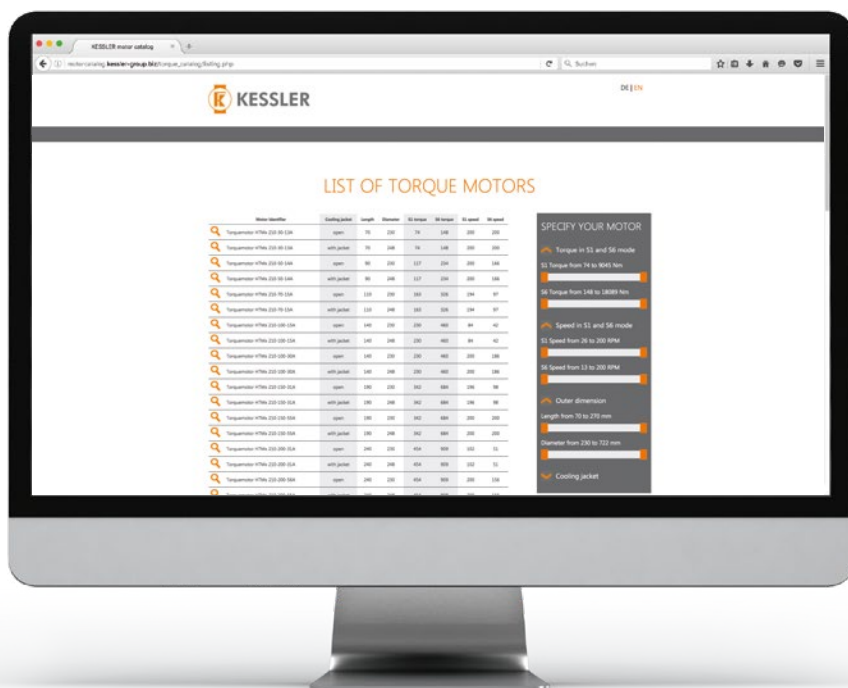

motorcatalog.kessler-group.biz

SLM linear motors

All advantages at a glance

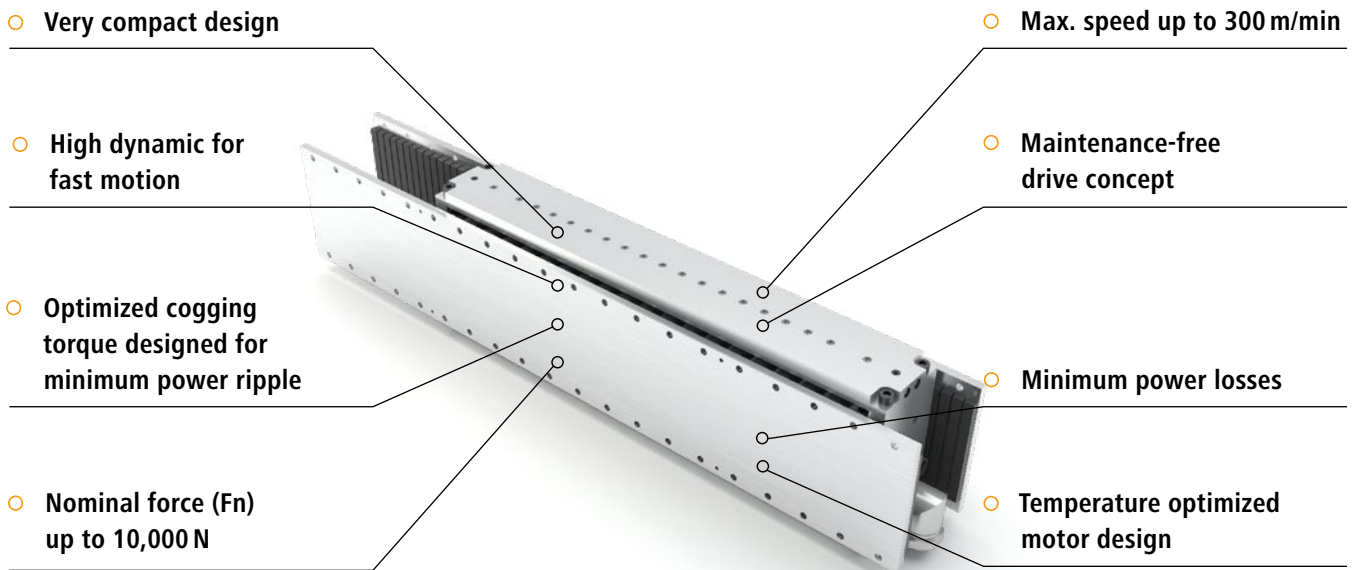

HIGH QUALITY



MADE IN GERMANY

SLM series

Model	Nominal force Fn (N)	Height (mm)	Width (mm)	Length (mm)
100 × 160	610	34	116	178
150 × 160	910	34	166	178
100 × 320	1,220	34	116	338
150 × 320	1,820	34	166	338
100 × 480	1,830	34	116	498
150 × 480	2,730	34	166	498

Other sizes available on request

KESSLER sets new standards with one-stop system solutions

We provide a wide range of asynchronous, synchronous, torque and linear motors, plus individually customized solutions.

The target merging of expertise into a core area focussing on motor technology, gives us the advantage of enhanced knowledge and the ability to bring together decisive components to form a powerful and comprehensive system.

This enables KESSLER to utilize specific branch-related cycles for the continual development of its products and to make future-oriented and pioneering technology available for a wide variety of application areas.



Examples of applications



Synchronous motor for electrical vehicle

Motor data:

- Torque S1: 800 Nm
- Maximum torque: 2,500 Nm
- Speed S1: 800 rpm
- Maximum speed: 1,500 rpm

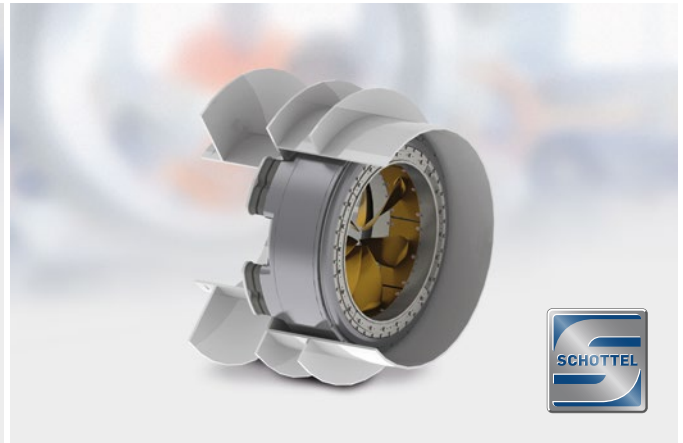

Torque motor for direct ship propulsion

Motor data:

- Torque S1: 6,090 Nm
- Maximum torque: 13,800 Nm
- Speed S1: 420 rpm
- Maximum speed: 494 rpm



Torque motor for biomass steam boiler

Motor data:

- Torque S1: 11,000 Nm
- Maximum torque: 15,500 Nm
- Speed S1: 40 rpm
- Maximum speed: 60 rpm

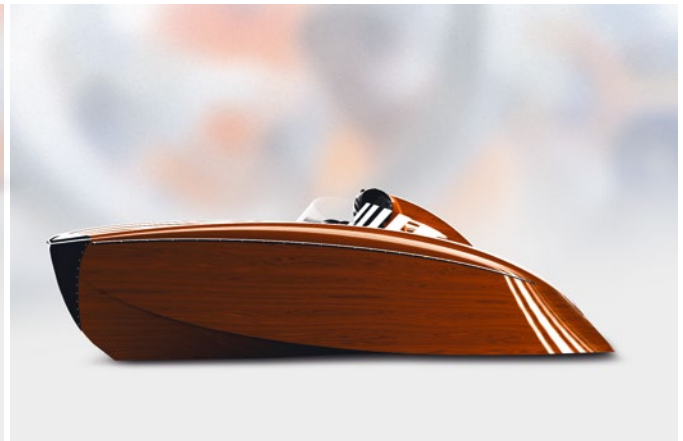

Synchronous motor for sport motor boat

Motor data:

- Torque S1: 200 Nm
- Maximum torque: 300 Nm
- Speed S1: 4,800 rpm
- Maximum speed: 4,800 rpm

Operating Worldwide for our Customers

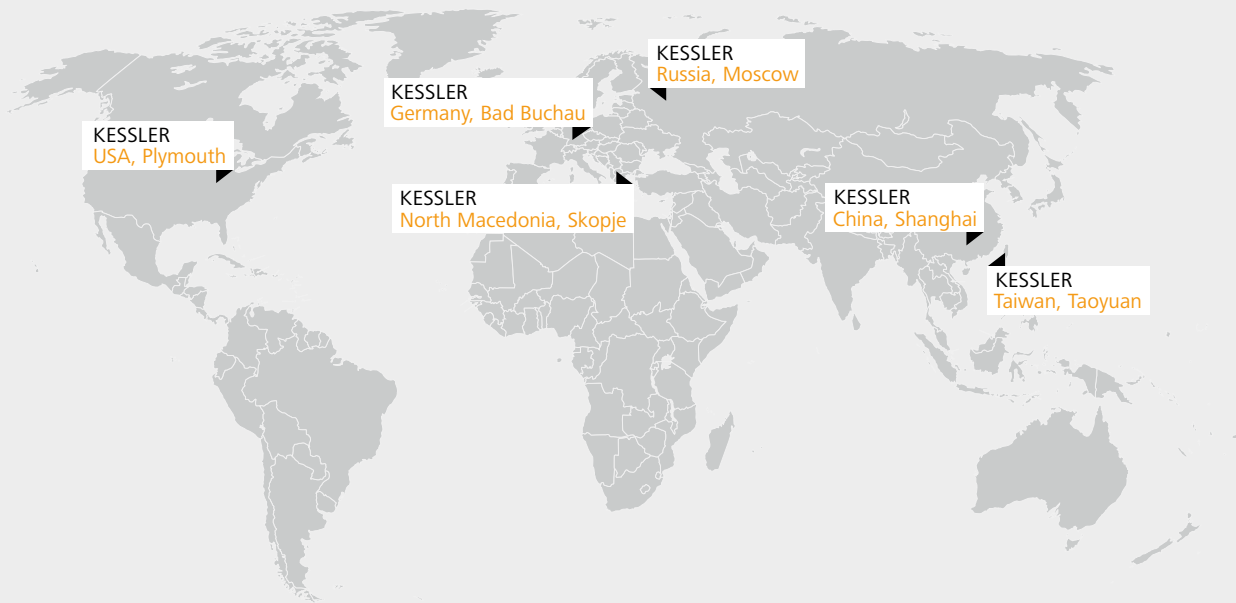

Germany

Franz Kessler GmbH
 Franz-Kessler-Straße 2
 88422 Bad Buchau, Germany
 Tel.: +49 7582 809 - 0
 Fax: +49 7582 809 - 170
 E-Mail: info@kessler-group.biz

KESSLER energy GmbH
 Franz-Kessler-Straße 2
 88422 Bad Buchau, Germany
 Tel.: +49 7582 809 - 0
 Fax: +49 7582 809 - 170
 E-Mail: info.energy@kessler-group.biz

North Macedonia

KESSLER Macedonia DOOEL Ilinden
 Str. 32, N.21, 1041 Ilinden, Skopje,
 Republic of North Macedonia
 Tel.: +389 71 381 863
Biljana.Andova@kessler-group.biz

USA

KESSLER USA Inc.
 44099 Plymouth Oaks Blvd.
 Plymouth, MI 48170, USA
 Tel.: +1 734 404 0152
 Fax: +1 734 404 0153
 E-Mail: info.usa@kessler-group.biz

Taiwan

KESSLER Taiwan Ltd.
 No.347, Sec. 1
 Nanshan Rd
 Luzhu District
 Taoyuan City 33861
 Taiwan (R.O.C.)
 Tel.: +886 3 326 2256
 Fax: +886 3 355 5014
 E-Mail: info.tw@kessler-group.biz

China

**KESSLER (Shanghai)
 Spindle Service Co., Ltd.**
 Building #12
 No.318 Yuanshan Rd
 Minhang District
 201108 Shanghai, China
 Tel.: +86 21 6489 7034
 Fax: +86 21 6489 7134
 E-Mail: info.cn@kessler-group.biz

Russia

KESSLER East Ltd.
 Dorogobuzhskaja str., 14, bld. 6
 121354, Moscow, Russia
 Tel.: +7 495 204 2450
 E-Mail: info.ru@kessler-group.biz